

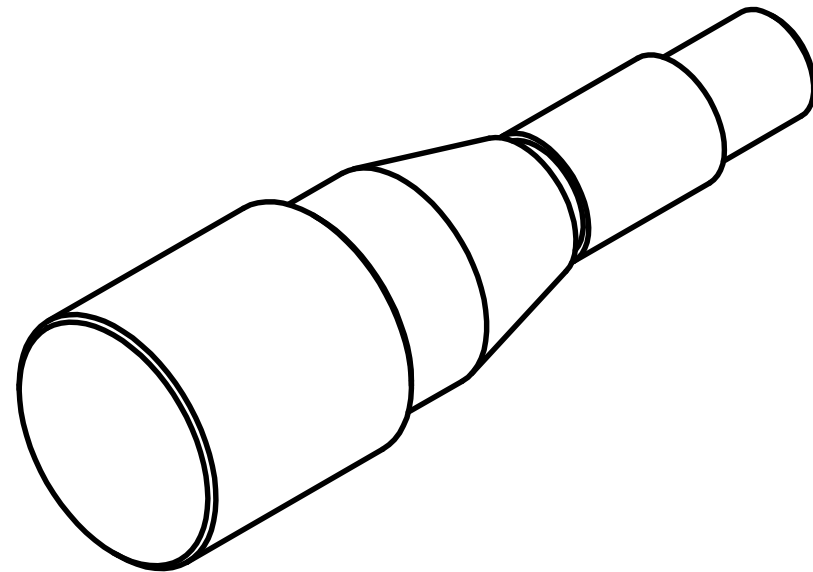

Grind threading tool
Grind grooving tool .125" (or less) wide.

Time to completion will be used as a tie breaker.



NOTES	ITEM NO.	MATERIAL	QTY.	TOLERANCE UNLESS OTHERWISE SPECIFIED	HEAT TREATMENT		SKILLS MANITOBA 2023
		SAE 12L14		FRAC. $\pm 1/64"$ X.X $\pm .050"$ X.XX $\pm .010"$ X.XXX $\pm .005"$ X.XXXX $\pm .0005"$	NONE		
SOLID EDGE ACADEMIC COPY					SCALE	BREAK ALL SHARP CORNERS	
					NTS	REMOVE ALL BURRS	
					DRAWN BY		
					W.PALMER		