

**NOTES:**

1. ALL MATERIALS LISTED ON ALL DRAWINGS REPRESENT INFORMATION AND DIMENSIONS FOR A FULL COURT AREA.  
(For the complete French translation of all the terms for this document, please see the Word document (Appendix A) posted on our Website)

1. LES MATÉRIAUX ÉNUMÉRÉS SUR TOUS LES DESSINS CONSTITUENT LES RENSEIGNEMENTS ET DIMENSIONS POUR UNE AIRE DE JEU PLEINE GRANDEUR.

(Pour la traduction complète en français de tous les termes de ce document, veuillez consulter le document Word (Annexe A) affiché à notre site Web)

|      |                           |     |           |
|------|---------------------------|-----|-----------|
| -    | -                         | -   | -         |
| -    | -                         | -   | -         |
| 0    | ISSUED FOR SCOPE DOCUMENT | SM  | JUL 31/22 |
| REV: | DESCRIPTION:              | BY: | DATE:     |

**REVISIONS**

PROJECT: SCNC WINNIPEG 2023 - ROBOTICS

SCNC\_RC\_2022\_1  
DRAWING NO.

T2023  
PROJECT NO.

07/31/22  
DATE.

DRAWING TITLE:  
OVERALL COURT LAYOUT

AS NOTED  
SCALE AT A4.

SM  
DRAWN.

DD  
CHECKED.

0  
REVISION.



**SKILLS CANADA**  
294 Albert Street, Suite 201  
Ottawa, Ontario  
1 (877) 754-5226

**NOTES:**

1. ALL MATERIALS LISTED ON ALL DRAWINGS REPRESENT INFORMATION AND DIMENSIONS FOR A FULL COURT AREA.

**KEYNOTES:**

- \* NOTED PIECES TO BE CONNECTED TOGETHER UTILIZING MENDING PLATES.
- \$ NOTED PIECES TO BE ANGLE CUT. SEE DIMENSIONS SHEET FOR DETAILS

① **MAIN STRUCTURAL PIECES LABELLING**  
SCALE = 1:40 (ON 8.5" x 11" PAPER)

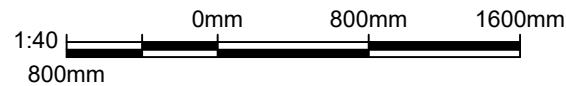

|      |                           |     |            |
|------|---------------------------|-----|------------|
| 0    | ISSUED FOR SCOPE DOCUMENT | SM  | JUL. 31/22 |
| REV: | DESCRIPTION:              | BY: | DATE:      |

**REVISIONS**

|  |                               |                      |                   |
|--|-------------------------------|----------------------|-------------------|
| PROJECT:<br><b>SCNC WINNIPEG 2023 - ROBOTICS</b> | SCNC_RC_2022_2<br>DRAWING NO. | T2023<br>PROJECT NO. | 07/31/22<br>DATE. |
| DRAWING TITLE:<br><b>PART LABELLING</b>          | AS NOTED<br>SCALE AT A4.      | SM<br>DRAWN.         | DD<br>CHECKED.    |
|  |                               |                      | 0<br>REVISION.    |



**SKILLS CANADA**  
294 Albert Street, Suite 201  
Ottawa, Ontario  
1 (877) 754-5226

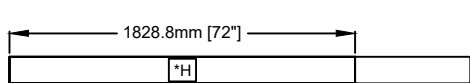
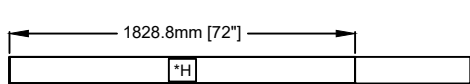
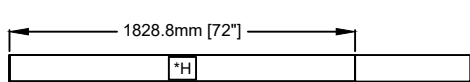
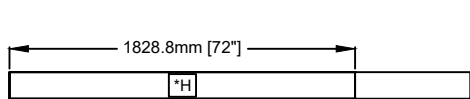
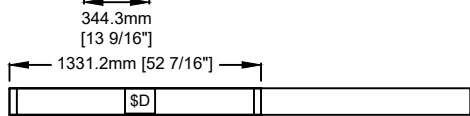
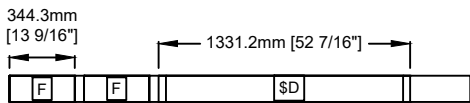
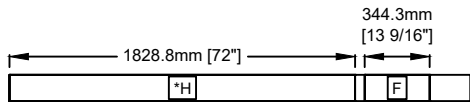
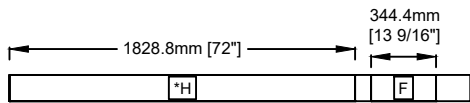

① 2x6" LUMBER DIMENSIONS  
SCALE = 1:40

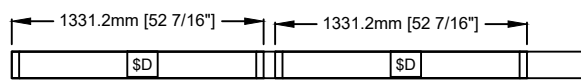
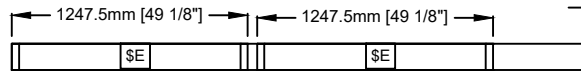

2x6x10's  
(QTY: 2)

② 2x6" LUMBER DIMENSIONS (CONT.)  
SCALE = 1:40

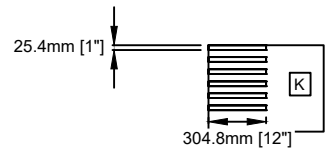

18" x 24"  
CORRUGATED  
PLASTIC SHEET  
(QTY: 1)



3" (I.D.)  
x 12"  
ABS  
PIPE

③ PLASTIC AND ABS DIMENSIONS  
SCALE = 1:40

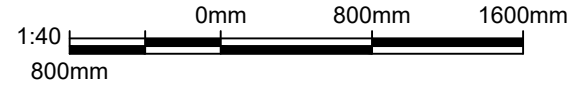

NOTES:

1. ALL MATERIALS LISTED ON ALL DRAWINGS REPRESENT INFORMATION AND DIMENSIONS FOR A FULL COURT AREA.

|      |                           |     |           |
|------|---------------------------|-----|-----------|
| -    | -                         | -   | -         |
| -    | -                         | -   | -         |
| 0    | ISSUED FOR SCOPE DOCUMENT | SM  | JUL 31/22 |
| REV: | DESCRIPTION:              | BY: | DATE:     |

REVISIONS

|   |                               |                      |                   |   |
|---|-------------------------------|----------------------|-------------------|---|
| PROJECT:<br><b>SCNC WINNIPEG 2023 - ROBOTICS</b>  | DRAWING NO.<br>SCNC_RC_2022_3 | PROJECT NO.<br>T2023 | DATE.<br>07/31/22 | <p><b>SKILLS CANADA</b><br/>294 Albert Street, Suite 201<br/>Ottawa, Ontario<br/>1 (877) 754-5226</p> |
| DRAWING TITLE:<br><b>PART DIMENSIONS (1 OF 2)</b> | AS NOTED<br>SCALE AT A4.      | SM<br>DRAWN.         | DD<br>CHECKED.    |   |

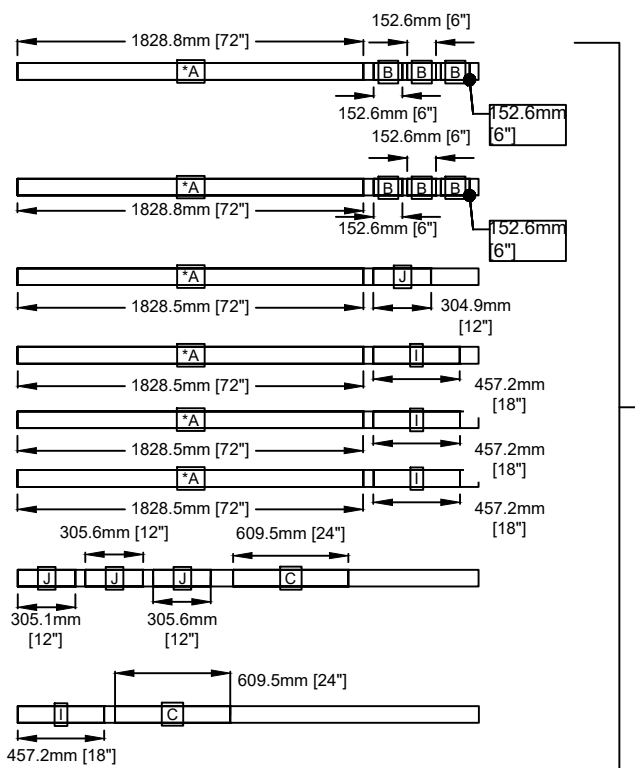

① 2x4" LUMBER DIMENSIONS  
SCALE = 1:40

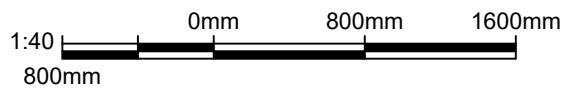

2x4x8's  
(QTY: 8)

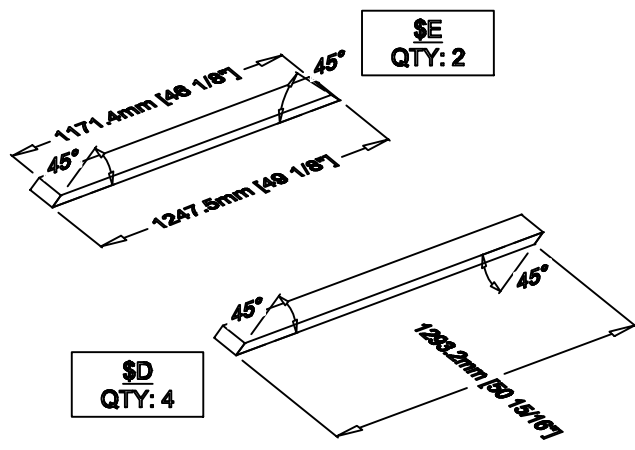

② 2x6" SPECIALTY PIECE ANGLED DIMENSIONS  
SCALE = N.T.S.

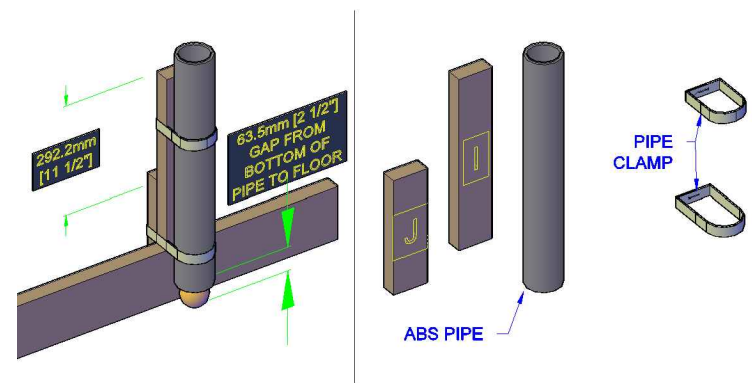

③ BALL DISPENSER DETAILS (EXPLODED)  
SCALE = N.T.S.

NOTES:

1. ALL MATERIALS LISTED ON ALL DRAWINGS REPRESENT INFORMATION AND DIMENSIONS FOR A FULL COURT AREA.

|           |                           |     |           |
|-----------|---------------------------|-----|-----------|
| REV:      | DESCRIPTION:              | BY: | DATE:     |
| -         | -                         | -   | -         |
| 0         | ISSUED FOR SCOPE DOCUMENT | SM  | JUL 31/22 |
| REVISIONS |                           |     |           |

PROJECT: SCNC WINNIPEG 2023 - ROBOTICS

SCNC\_RC\_2022\_4  
DRAWING NO.

T2023  
PROJECT NO.

07/31/22  
DATE.

DRAWING TITLE:  
PART DIMENSIONS (2 OF 2)

AS NOTED  
SCALE AT A4.

SM  
DRAWN.

DD  
CHECKED.

0  
REVISION.



**SKILLS CANADA**  
294 Albert Street, Suite 201  
Ottawa, Ontario  
1 (877) 754-5226

**NOTES:**

1. ALL MATERIALS LISTED ON ALL DRAWINGS REPRESENT INFORMATION AND DIMENSIONS FOR A FULL COURT AREA.

| <b>2023 Skills National Robotics Competition: Bill of Materials (1 Court)</b> |                 |   |
|---|-----------------|---|
| <b>Description<sup>2</sup></b>  | <b>Quantity</b> | <b>Web Url</b>  |
| 2" x 6" x 10' Standard SPF Dimension Lumber                                   | 2               | <a href="https://bit.ly/306D9cx">https://bit.ly/306D9cx</a>   |
| 2" x 6" x 8' Standard SPF Dimension Lumber                                    | 8               | <a href="https://bit.ly/2BzgyvA">https://bit.ly/2BzgyvA</a>   |
| 2" x 4" x 8' Standard SPF Dimension Lumber                                    | 8               | <a href="https://bit.ly/2OZZstZ">https://bit.ly/2OZZstZ</a>   |
| 0.157-inch x 24-inch x 48-inch White Corrugated Plastic Sheet                 | 1               | <a href="https://bit.ly/3BKQIHl">https://bit.ly/3BKQIHl</a>   |
| 3" (I.D.) x 12' ABS Pipe (Cell Core)  | 1               | <a href="https://bit.ly/3bgi2ki">https://bit.ly/3bgi2ki</a>   |
| 5 - 7 in. Stainless Steel Hose Clamp  | 8               | <a href="https://thd.co/3PP76oJ">https://thd.co/3PP76oJ</a>   |
| MP 2 inch x 4 inch 20-Gauge Galvanized Mending Plate                          | 4               | <a href="https://bit.ly/3Q5c4gJ">https://bit.ly/3Q5c4gJ</a>   |
| Steel Mini Hockey Net   | 6               | <a href="https://amzn.to/3JghRhi">https://amzn.to/3JghRhi</a> |
| NHL Street Hockey Balls (Bag of 15)   | 2               | <a href="https://amzn.to/3zHTQwE">https://amzn.to/3zHTQwE</a> |
|   |                 |   |
|   |                 |   |
|   |                 |   |

**① BILL OF MATERIALS**  
SCALE = N/A

|      |                           |     |           |
|------|---------------------------|-----|-----------|
| -    | -                         | -   | -         |
| -    | -                         | -   | -         |
| 0    | ISSUED FOR SCOPE DOCUMENT | SM  | JUL 31/22 |
| REV: | DESCRIPTION:              | BY: | DATE:     |

**REVISIONS**

|  |                               |                      |                   |
|--|-------------------------------|----------------------|-------------------|
| PROJECT:<br><b>SCNC WINNIPEG 2023 - ROBOTICS</b> | SCNC_RC_2022_5<br>DRAWING NO. | T2023<br>PROJECT NO. | 07/31/22<br>DATE. |
| DRAWING TITLE:<br><b>OVERALL COURT LAYOUT</b>    | AS NOTED<br>SCALE AT A4.      | SM<br>DRAWN.         | DD<br>CHECKED.    |
|  |                               | 0<br>REVISION.       |                   |



**SKILLS CANADA**  
294 Albert Street, Suite 201  
Ottawa, Ontario  
1 (877) 754-5226